

DRIACOATER®

for sugar, sugar-free and polishing applications



DRIACOATER® for sugar, sugar-free and polishing applications

Batch handling

The DRIACOATER handles batches prior to coating, during coating, and post coating to ensure that the coating drum is being fully utilized for coating.

The DRIACOATER is thus capable to hold three different batches and is equipped with fast loading and discharge devices. This approach greatly increases the efficiency of the machine and shortens your process time.

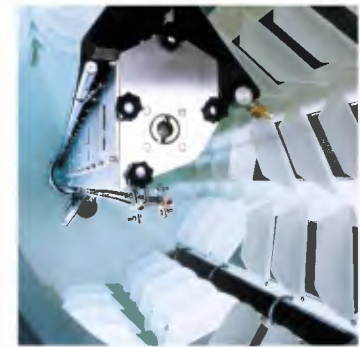
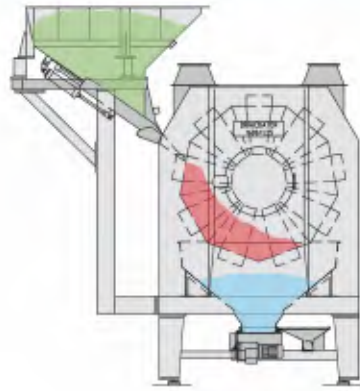

The spray bar is mounted in the center of the pan and is equipped with its own housing. Some of the benefits include cleaning within the housing and easy removal of the spray bar.

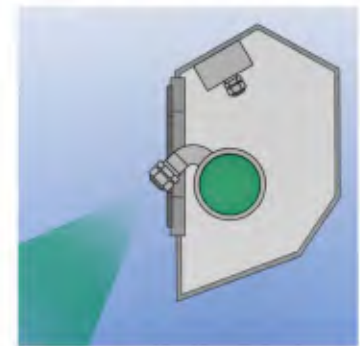

The spray bar pivots back into the housing for cleaning of the nozzle tips.

Spray bar function

DRIAM offers a wide range of spray bars for various coating applications. The patented spray bar with its superior functionality is designed to ensure that all centers are coated evenly.

The solution spray bar turns back in the housing for cleaning of the nozzle tips which prevents any blockages. The spray bar can also be easily retracted if access to the nozzles is needed.

The DRIACOATER is the industry standard automated coating system and numerous turnkey coating systems are in operation around the globe.

The DRIACOATER® is a highly flexible and efficient automated coater which is specially designed for sugar and sugar-free coating applications. Typical coating applications include sugar coated chocolate lentils, chewing gum, liquid filled centers, film coating and polishing.

The state-of-the-art system has undergone many improvements over the past decades. New features and options are being added every year to reap the best results in coating quality, reproducibility, efficiency, flexibility and practicality. The sanitary design of the machine ensures that it meets all GMP requirements.

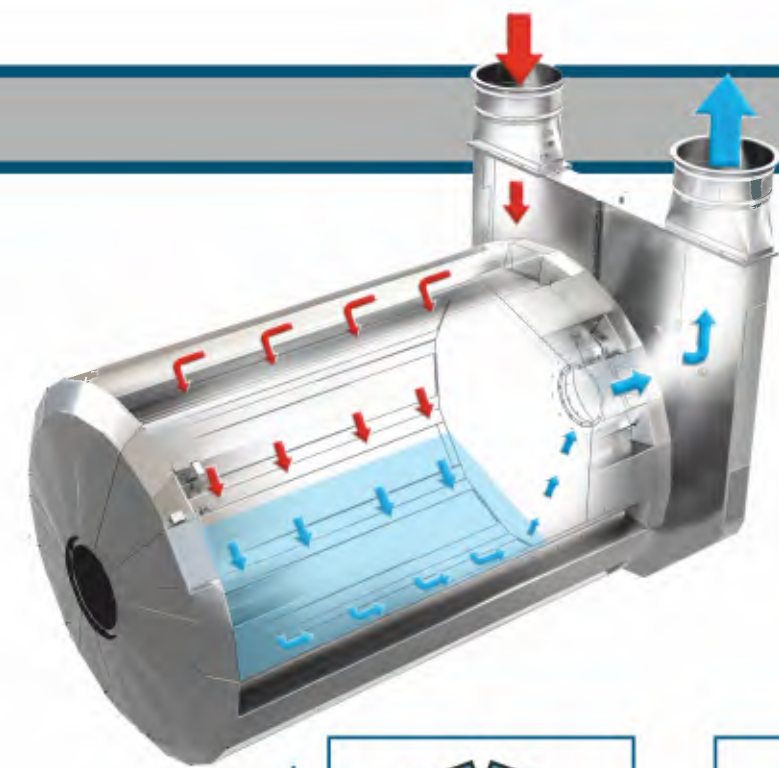

Conditioned drying air is forced through the product bed by means of air channels sitting on the perforated sections of the drum.



Loading hopper

Load cells

Air ventilation

Pan with air ducts

Suspension tanks

Discharge container

Control

Safety window

Spray bar

Powder doser

Discharge device

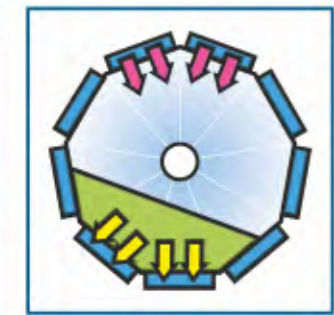

Direct air flow
The air is forced from the top through the product bed with air exhaust at the bottom.



Reverse air flow
The air is forced from the bottom through the product bed with air exhaust at the top.

Process and air handling in the DRIACOATER

The air handling system has a tremendous impact on the coating quality and operating costs.

The DRIACOATER has a superior air flow system that takes nearly 100% of the process air from the air handler and applies it evenly to all products being coated. This efficiency is achieved by using high pressure fans that force all of the drying air against the resistance of product bed. This process requires a tight seal and is achieved using air ducts that are installed all around the pan.

The air channel system has been proven to be the most superior method to efficiently distribute the process air over the entire product bed.

The efficient use of air with the DRIACOATER provides substantial cost savings over the entire life of the machine.

DRIACOATER[®]

for sugar, sugar-free and polishing applications



Discharge options

Various discharge devices are available to store and move the product from the coater. The handling of product should be done carefully and in a defined environment.

If post-conditioning is required, options are available to reduce drying and process time for the coater.



Unloading into several mobile containers



Unloading by vibration chute mounted underneath the unloading hopper



Unloading by flat belt and ascending belt

Customers enjoy these benefits by using the DRIACOATER technology:

- Ideal for sugar, sugar-free, soft sugar, polishing and many other applications
- Most efficient use of process air through equal distribution across the entire product bed
- Highly automated recipe driven technology which minimizes operator's workload
- Very reliable and running 24/7 with low maintenance demands
- Fast material handling devices incorporated to save process time
- Low energy consumption and superior energy balance
- Marginal loss of process air in the air channels resulting in almost 100% use of process air
- Dust-free operation as a result of efficient extraction
- Enclosed system which is completely controlled; this allows the unit to be recipe driven as it is independent from environmental conditions
- Patented CIP spray bar
- Complete hygienic design that meets all GMP requirements

Batch sizes^{*)} available:

- ⑩ 500 kg
- ⑩ 1000 kg
- ⑩ 2000 kg
- ⑩ 3000 kg

^{*)} based on 800 g/liteR

